

Data Sheet



Article number: 2308051551

Description: E+G Index plunger
PMT.100-SST-5-M10x1-A

Measures

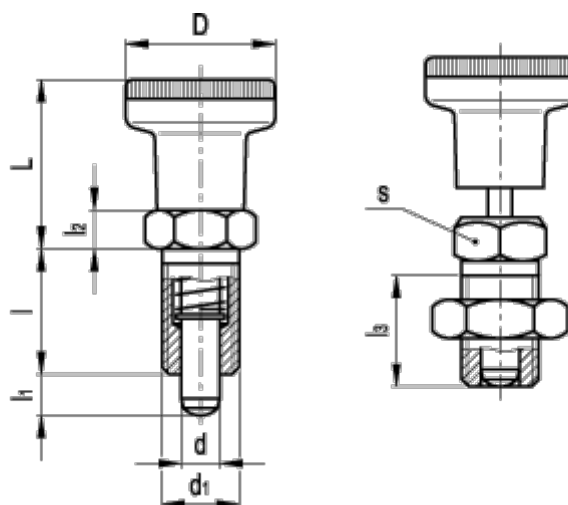

Code = PMT.100-5-M10x1-SST-A

D = 21

d = 5

d1 = M10x1

l = 17

L = 23

l1 = 5

l2 = 5

l3 = 15

Max. axial load (N) = 15

s = 12